



2" INLINE BPR. Back Pressure Regulator (NEW STYLE)

772 2-INL

The Baird 772 Inline Back Pressure Regulator has the same applications as our 772-2-T Type Regulator. Please refer to page 15 of this catalog for information.

BODY: 2" Ductile Iron or Aluminum-Bronze

BALL & SEAT: Stainless

INLET: 2" Female NPT

OUTLET: 2" Female NPT

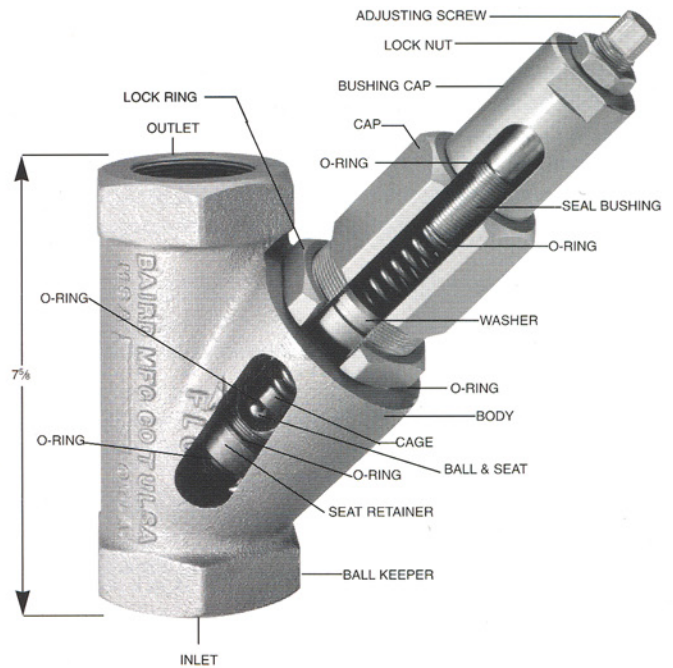

DUCTILE IRON PART NUMBER	WORKING PRESSURE RANGE	SEAT ORIFICE DIAMETER
772 2-INL-D-2	5-200#	7/8"
772 2-INL-D-5	10-500#	7/8"
772 2-INL-D-9	25-900#	7/8"
772 2-INL-D-15	200-1500#	11/16"
772 2-INL-D-25	1500-2500#	11/16"

MATERIAL SPECIFICATIONS:

- **Standard valve is** Ductile Iron with Stainless Ball & Seat for normal conditions.
- **Add "AB" to part number** for Aluminum-Bronze with Stainless trim and Seralloy® (Cobalt Base Alloy) Ball & Seat for corrosive or salt water environments.

REPAIR KITS:

- K1** Includes all O-rings.
- K2** Includes all O-rings and Ball & Seat.
- K3** Includes all O-rings, Ball & Seat, Spring, Ball Keeper, and Spring Washer.
- K4** Includes all O-rings, Ball & Seat, Spring, Ball Keeper, Seat Retainer, Cage, and Spring Washer.

Note: When converting to or from a 772-2-INL-D-25, the K4 Kit is required.

(If a pressure change is desired, order the K3 Kit)